

Operating and Service Manual

Agilent Technologies

85130F

**NMD 2.4 mm to 3.5 mm
Adapter Kit**



Part Number 85130-90030

Printed in USA

May 1988

© Copyright 1988 Agilent Technologies

WARRANTY

This Hewlett-Packard instrument product is warranted against defects in material and workmanship for a period of one year from date of delivery. During the warranty period, Hewlett-Packard Company will, at its option, either repair or replace products which prove to be defective.

For warranty service or repair, this product must be returned to a service facility designated by HP. Buyer shall prepay shipping charges to HP and HP shall pay shipping charges to return the product to Buyer. However, Buyer shall pay all shipping charges, duties, and taxes for products returned to HP from another country.

HP warrants that its software and firmware designated by HP for use with an instrument will execute its programming instructions when properly installed on that instrument. HP does not warrant that the operation of the instrument, or software, or firmware will be uninterrupted or error free.

LIMITATION OF WARRANTY

The foregoing warranty shall not apply to defects resulting from improper handling by Buyer, **Buyer**-supplied software or interfacing, unauthorized modification or misuse, or operation outside of the environmental specifications for the product.

NO OTHER WARRANTY IS EXPRESSED OR IMPLIED, HP SPECIFICALLY DISCLAIMS THE IMPLIED WARRANTIES OR MERCHANTABILITY AND FITNESS FOR A PARTICULAR PURPOSE.

EXCLUSIVE REMEDIES

THE REMEDIES PROVIDED HEREIN ARE BUYER'S SOLE AND EXCLUSIVE REMEDIES, HP SHALL NOT BE LIABLE FOR ANY DIRECT, INDIRECT, SPECIAL, INCIDENTAL, OR CONSEQUENTIAL DAMAGES, WHETHER BASED ON CONTRACT, TORT, OR ANY OTHER LEGAL THEORY.

ASSISTANCE

*Product maintenance agreements and other customer assistance agreements are available for **Hewlett-Packard** Products.*

*For any assistance, contact your nearest Hewlett-Packard Sales and Service **Office**. Addresses are provided at the back of this manual.*

Notice

Hewlett-Packard to Agilent Technologies Transition

This documentation supports a product that previously shipped under the Hewlett-Packard company brand name. The brand name has now been changed to Agilent Technologies. The two products are functionally identical, only our name has changed. The document still includes references to Hewlett-Packard products, some of which have been transitioned to Agilent Technologies.



Agilent Technologies

HP 85130F Adapter Kit

GENERAL INFORMATION

To obtain optimum performance from this adapter kit, observe these simple precautions:

- Make connections carefully to avoid misalignment and connector damage, which will result in inaccurate measurements.
- Keep the connectors free of dirt and any particles.
- When you clean the connectors, try compressed air first. Do not use abrasives. With a clean foam swab, apply **only** Freon TF as a solvent.
- For more information, refer to the Microwave Connector Care manual.

DESCRIPTION

The HP 85130F adapter kit consists of two NMD-2.4 mm to 3.5 mm adapters and a spanner wrench. The test set end of the adapters has a NMD-2.4 mm connector while the Device Under Test (DUT) end has a precision connector. The NMD-2.4 mm to NMD-3.5 mm (m) adapter is used when a male test port is required. The NMD-3.5 mm to PSC-3.5 (f) (precision **slotless** connector) adapter is used when a female test port is required.

CONTENTS

The HP 85130F kit contains the following:

Description	Quantity	Replacement Part Number
Test port adapters		
NMD-2.4 mm to NMD-3.5 mm (m)	1	85130-60010
NMD-2.4 mm to PSC-3.5 (f)	1	85130-60011
Storage box, foam lined	1	85130-60013
Operating and Service Manual	1	85130-90030
Spanner wrench	1	08513-20014

SPECIFICATIONS

Hewlett-Packard guarantees that your adapters will equal or exceed the following specifications:

Table 1. HP 85130F Specifications

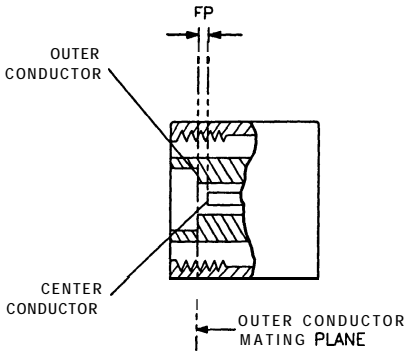
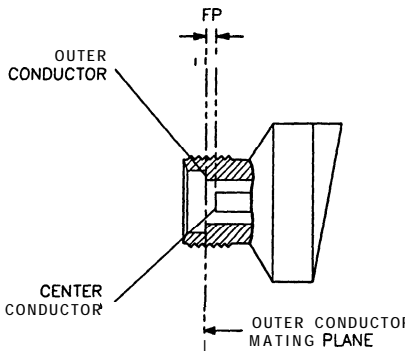
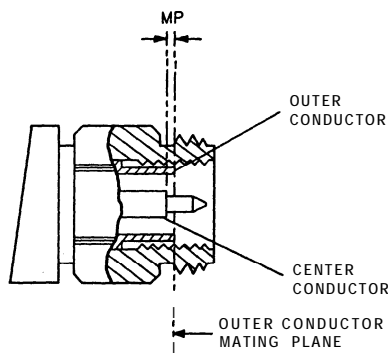
CENTER CONDUCTOR PROTRUSION		
No center conductor shoulder (male pin end of female center pin) protrusion is allowable on any connector.		
CENTER CONDUCTOR RECESSION		
NMD-2.4 mm Female 	PSC-3.5 Female 	NMD-3.5 mm Male 
MP = male contact pin shoulder recession behind the outer conductor mating plane. FP = recession of the end of female center pin behind the outer conductor mating plane.		
Connector	Allowable Recession	
	mm	in
NMD-2.4 mm female	+0.000 to +0.056	+0.000 to +0.0022
PSC-3.5 female	+ 0.00254 to + 0.0127	+0.0001 to +0.0005
NMD-3.5 mm male	+ 0.00254 to + 0.0127	+0.0001 to +0.0005
ELECTRICAL		
Adapter	Frequency Range	Return Loss
NMD-2.4 mm to PSC-3.5 female and	DC to 8 GHz	≥32 dB
	8 GHz to 18 GHz	≥28 dB
NMD-2.4 mm to NMD-3.5 mm male	18 GHz to 26.5	≥26 dB

PERFORMANCE TESTS

Using an HP 8510 Network Analyzer perform the following test on your adapters as soon as you receive them, and periodically repeat the test to determine if their performance meets the electrical specifications stated above or if they need to be replaced. An initial period of one year between performance tests is recommended.

Required Equipment	HP Model/Part Number
HP 8510B Network Analyzer	HP 8510 Option 010
with time domain option and B.04.0X firmware or higher	
HP 8516A S-parameter Test Set	
HP 834XX Synthesized Sweeper	
NOTE: Refer to the HP 8516A Operating and Service Manual for information on instrument compatibility.	
3.5 mm loads	
(part of the HP 850528 calibration kit)	
male	85052-60010
female	85052-60010
3.5 mm 50Ω airline, 7.5 cm	
(part of the HP 850538 verification kit) 85053-60005	

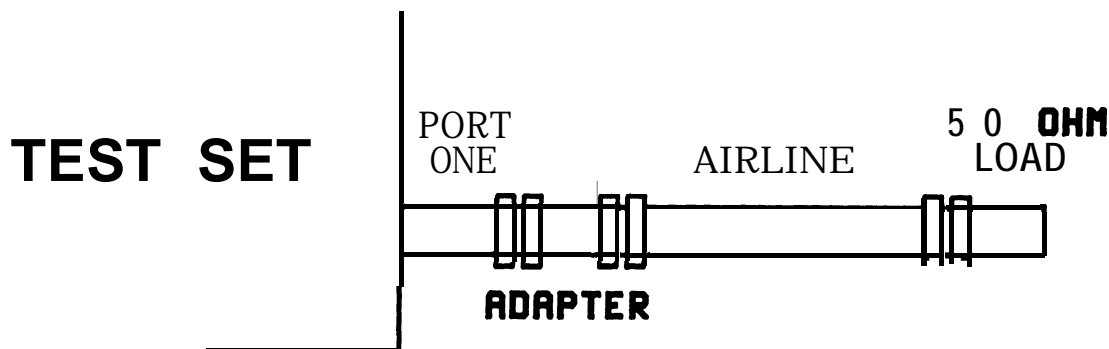

Figure 1. Return Loss Set-up

Return loss is measured by connecting a **50-ohm** fixed load termination through a 7.5 cm airline to the adapter, then attaching the adapter to port one of the test set (see Figure 7).

The effects of an imperfect load may be gated out using the HP 8510 time domain option as follows:

1. Press **[PRESET]**. The HP 8510 will be set to a predetermined state.
2. Under STIMULUS, press **[START] [4] [5] [M/μ]**. This sets the start frequency to 45 MHz.
3. Under STIMULUS, press **[STOP] [2] [6] [.] [5] [G/n]**. This sets the stop frequency to 26.5 GHz.
4. Perform a 2.4 mm one port sliding load **S11** calibration with 32 averaging at port one of your test set, as described in the HP 8510 Operating and Programming manual. Save the calibration. Set up as shown in Figure 1.

5. With correction turned on, under MENUS, press **[DOMAIN]**. This brings up a set of time domain and frequency functions to the softkeys. Select **[TIME BANDPASS]**. This puts you in time domain mode.
6. Under STIMULUS, press **[START] [-] [.] [0] [5] [G/n]**. This sets the start time of the sweep to **-.05** nanoseconds.
7. Under STIMULUS, press **[STOP] [1] [G/n]**. This sets the stop time of the sweep to 1 nanosecond.
8. Under RESPONSE, press **[AUTO]**. This brings the trace on screen.
9. Under the **softkey** functions, press **[SPECIFY GATE]**. A new menu should appear that will allow you to press **[STOP]** **softkey**.
10. Using the RPG, adjust the stop gate to the center of the airline (see Figure 2).
11. Under the **softkey** functions press **[GATE ON]**. The HP 8510 will now compute the gate coefficients to gate out everything but the adapter.
12. Press the **[PRIOR MENU]** button just to the right of the **softkeys** and a new menu should appear that will allow you to press the **[FREQUENCY]** **softkey**.
13. Under MENUS, press **[MARKER]**. This brings up a set of functions to the softkeys. Select **[MORE]** **[MAXIMUM]** **softkeys**.
14. You can now read the return loss value from the screen marker value, and record the results on the Performance Test Record provided.

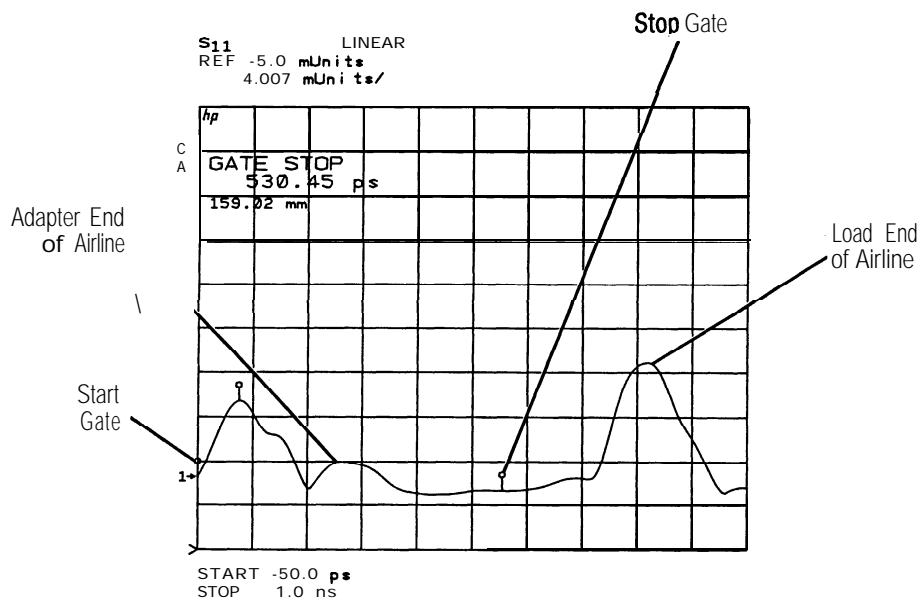

Figure 2. Location of Gates and Airline

Performance Test Record

ELECTRICAL SPECIFICATIONS		Tested by: _____	
		Date: _____	
Adapter	Frequency Range	Return Loss	Measured
NMD-2.4 mm to PSC-3.5 female and NMD-2.4 mm to NMD-3.5 mm male	DC to 8 GHz	≥32 dB	
	8 GHz to 18 GHz	≥28 dB	
	18 GHz to 26.5 GHz	≥26 dB	

PROPER USE

Attach the adapters to the test ports and tighten them finger tight. Use the spanner wrench to hold the test set end of the adapter and torque the test set connector with a 20 mm torque wrench set to 96 N-cm (8 in-lb). Attach a non-rotating clamp to each test port.

REPLACEABLE PARTS

There are no replaceable parts in the HP 85130F adapter kit. A worn or damaged adapter must be replaced in whole.

EQUIPMENT AND SUPPLIES

The following equipment and supplies are required for the maintenance and use of, but are not supplied with, your HP 85130F adapter kit.

- 3.5 mm gage kit 85052-80010
(part of the HP 85052A/B calibration kits)
- Torque wrench, 20 mm, 96 N-cm (8 in-lb) 8710-1764
- Torque wrench, 5/16 inch, 96 N-cm (8 in-lb) 8710-1765
(part of the HP 85052A/B calibration kits)
- Microwave Connector Care Manual 08510-90064
- Connector cleaning kit 92193Z
- Non-rotating Clamp 08515-60003
(two included with the HP 8516A test set)